

FIRE HOSE CABINET COMPLETE SETS PRESTIGE®

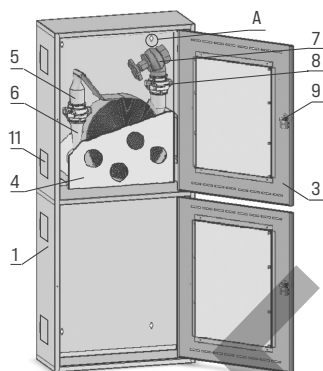

Fig.1 -
Fire Hose Cabinet Complete Set
PRESTIGE 03-W

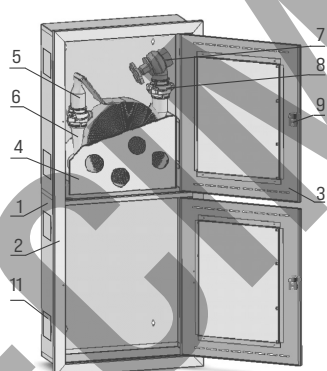

Fig.2 -
Fire Hose Cabinet Complete Set
PRESTIGE 03-R

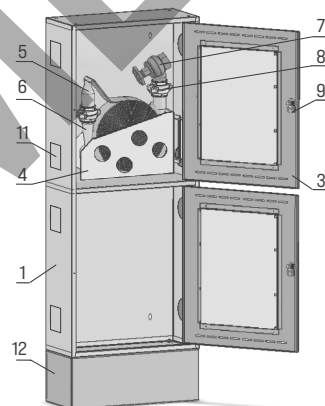

Fig.3 -
Fire Hose Cabinet Complete Set
PRESTIGE 03-F

1. PRODUCT DESIGNATION

Fire Hose Cabinet Complete Sets are intended for formation and delivery of a jet of an extinguishing agent (water) to the source of ignitions. Fire Hose Cabinet Complete Sets are equipped with fire shutoff valves and connected to the fire water supply network.

ATTENTION: IT IS NOT ALLOWED TO USE FIRE HOSE CABINET COMPLETE SETS TO EXTINGUISH ELECTRICAL EQUIPMENT AND WIRING UNDER VOLTAGE. DISCONNECT IT FROM THE POWER SUPPLY NETWORK FIRST.

2. DELIVERY SET

Designation of Fire Hose Cabinet Complete Sets:

Fire Hose Cabinet Complete Set «PRESTIGE-X-X-X-X-X» TR BY X

Fire cabinet size (01, 02, 03)	
Fire cabinet mounting method (W – wall-mounted, R – recessed, F – floor-mounted)	
Nominal diameter of the applied fire hose (50 (51) или 65 (66))	
Designation of a hand fire nozzle	
Number of fire valves (only for sets completed with two fire valves) [2V]	
Designation of technical requirements	

Example of ordering a Fire Hose Cabinet Complete Sets:

Fire Hose Cabinet Complete Set «PRESTIGE-03-W-51-RS-50» TR BY 300376711.022-2008 denotes the supply of a complete set with a fire hose with a nominal pass of 51 mm, with a nozzle RS-50 placed in a cabinet of standard size 03, wall-mounted.

Designation of Fire Hose Cabinet Complete Set			Designation of components			
Standard size	Fire Hose Cabinet Complete Set Modification	Fire cabinet	Complete fire hose	Hand nozzle	Valve	Coupling
1	2	3	4	5	6	7
PRESTIGE-03-W-RS	PRESTIGE-03-WGR-51-RS-50	PRESTIGE-03-WGR	PRESTIGE 51-1,0-OP-PK	RS-50	KPK 50-02	GM-50
	PRESTIGE-03-WGW-51-RS-50	PRESTIGE-03-WGW				
	PRESTIGE-03-WSR-51-RS-50	PRESTIGE-03-WSR				
	PRESTIGE-03-WSW-51-RS-50	PRESTIGE-03-WSW				
	PRESTIGE-03-WGR-66-RS-70	PRESTIGE-03-WGR	PRESTIGE 66-1,0-OP-PK	RS-70	KPK 65-02	GM-70
	PRESTIGE-03-WGW-66-RS-70	PRESTIGE-03-WGW				
	PRESTIGE-03-WSR-66-RS-70	PRESTIGE-03-WSR				
	PRESTIGE-03-WSW-66-RS-70	PRESTIGE-03-WSW				

1	2	3	4	5	6	7
PRESTIGE-03-R-RS	PRESTIGE -03-RGR-51-RS-50	PRESTIGE -03-RGR	PRESTIGE 51-1,0-0P-PK	RS-50	KPK 50-02	GM-50
	PRESTIGE -03-RGW-51-RS-50	PRESTIGE -03-RGW				
	PRESTIGE -03-RSR-51-RS-50	PRESTIGE -03-RSR				
	PRESTIGE -03-RSW-51-RS-50	PRESTIGE -03-RSW				
	PRESTIGE -03-RGR-66-RS-70	PRESTIGE -03-RGR	PRESTIGE 66-1,0-0P-PK	RS-70	KPK 65-02	GM-70
	PRESTIGE -03-RGW-66-RS-70	PRESTIGE -03-RGW				
	PRESTIGE -03-RSR-66-RS-70	PRESTIGE -03-RSR				
	PRESTIGE -03-RSW-66-RS-70	PRESTIGE -03-RSW				
PRESTIGE-03-F-RS	PRESTIGE-03-FOR-51-RS-50	PRESTIGE-03-FOR	PRESTIGE 51-1,0-0P-PK	RS-50	KPK 50-02	GM-50
	PRESTIGE-03-FGW-51-RS-50	PRESTIGE-03-FGW				
	PRESTIGE-03-FSR-51-PC-50	PRESTIGE-03-FSR				
	PRESTIGE-03-FSW-51-RS-50	PRESTIGE-03-FSW				
	PRESTIGE-03-FGR-66-RS-70	PRESTIGE-03-FGR	PRESTIGE 66-1,0-0P-PK	RS-70	KPK 65-02	GM-70
	PRESTIGE-03-FGW-66-RS-70	PRESTIGE-03-FGW				
	PRESTIGE-03-FSR-66-RS-70	PRESTIGE-03-FSR				
	PRESTIGE-03-FSW-66-RS-70	PRESTIGE-03-FSW				
PRESTIGE-03-W-RS.01	PRESTIGE-03-WGR-51-RS-50.01	PRESTIGE-03-WGR	PRESTIGE 51-1,0-0P- PK-RS	RS-50.01	KPK 50-02	GM-50
	PRESTIGE-03-WGW-51-RS-50.01	PRESTIGE-03-WGW				
	PRESTIGE-03-WSR-51-RS-50.01	PRESTIGE-03-WSR				
	PRESTIGE-03-WSW-51-RS-50.01	PRESTIGE-03-WSW				
PRESTIGE-03-R-RS.01	PRESTIGE-03-RGR-51-RS-50.01	PRESTIGE-03-RGR	PRESTIGE 51-1,0-0P- PK-RS	RS-50.01	KPK 50-02	GM-50
	PRESTIGE-03-RGW-51-RS-50.01	PRESTIGE-03-RGW				
	PRESTIGE-03-RSR-51-RS-50.01	PRESTIGE-03-RSR				
	PRESTIGE-03-RSW-51-RS-50.01	PRESTIGE-03-RSW				
PRESTIGE-03-F-RS.01	PRESTIGE-03-FGR-51-RS-50.01	PRESTIGE-03-FGR	PRESTIGE 51-1,0-0P- PK-RS	RS-50.01	KPK 50-02	GM-50
	PRESTIGE-03-FGW-51-RS-50.01	PRESTIGE-03-FGW				
	PRESTIGE-03-FSR-51-RS-50.01	PRESTIGE-03-FSR				
	PRESTIGE-03-FSW-51-RS-50.01	PRESTIGE-03-FSW				

3. MAIN TECHNICAL DATA AND CHARACTERISTICS

Designation of Fire Hose Cabinet Complete Set	Appearance characteristics of the cabinet			Mass of the Set, kg not more	Size of the Set, mm not more
	Cabinet model	Color	Availability of window		
1	2	3	4	5	6
PRESTIGE-03-WGR-51-RS-50	Wall-mounted	red	glass	35,6	540 x 1280 x 230
PRESTIGE-03-WGW-51-RS-50		white			
PRESTIGE-03-WSR-51-RS-50		red	solid	34,8	
PRESTIGE-03-WSW-51-RS-50		white			
PRESTIGE-03-WGR-66-RS-70		red	glass	39,2	
PRESTIGE-03-WGW-66-RS-70		white			
PRESTIGE-03-WSR-66-RS-70		red	solid	38,4	
PRESTIGE-03-WSW-66-RS-70		white			
PRESTIGE-03-WGR-51-RS-50	Recessed	red	glass	38,3	590 x 1330 x 250
PRESTIGE-03-WGW-51-RS-50		white			
PRESTIGE-03-WSR-51-RS-50		red	solid	37,4	
PRESTIGE-03-WSW-51-RS-50		white			
PRESTIGE-03-WGR-66-RS-70		red	glass	41,9	
PRESTIGE-03-WGW-66-RS-70		white			
PRESTIGE-03-WSR-66-RS-70		red	solid	41,0	
PRESTIGE-03-WSW-66-RS-70		white			
PRESTIGE-03-RGR-51-RS-50	Floor-mounted	red	glass	40,7	540 x 1480 x 230
PRESTIGE-03-RGW-51-RS-50		white			
PRESTIGE-03-FSR-51-RS-50		red	solid	39,9	
PRESTIGE-03-FSW-51-RS-50		white			
PRESTIGE-03-FGR-66-RS-70		red	glass	44,3	
PRESTIGE-03-FGW-66-RS-70		white			
PRESTIGE-03-FSR-66-RS-70		red	solid	43,5	
PRESTIGE-03-FSW-66-RS-70		white			

1	2	3	4	5	6
PRESTIGE-03-WGR-51-RS-50.01	Wall-mounted	red	glass	34,9	540 x 1280 x 230
PRESTIGE-03-WGW-51-RS-50.01		white			
PRESTIGE-03-WSR-51-RS-50.01		red	solid	34,1	
PRESTIGE-03-WSW-51-RS-50.01		white			
PRESTIGE-03-RGR-51-RS-50.01	Recessed	red	glass	37,6	590 x 1330 x 250
PRESTIGE-03-RGW-51-RS-50.01		white			
PRESTIGE-03-RSR-51-RS-50.01		red	solid	36,7	
PRESTIGE-03-RSW-51-RS-50.01		white			
PRESTIGE-03-FGR-51-RS-50.01	Floor-mounted	red	glass	40,0	540 x 1480 x 230
PRESTIGE-03-FGW-51-RS-50.01		white			
PRESTIGE-03-FSR-51-RS-50.01		red	solid	39,2	
PRESTIGE-03-FSW-51-RS-50.01		white			

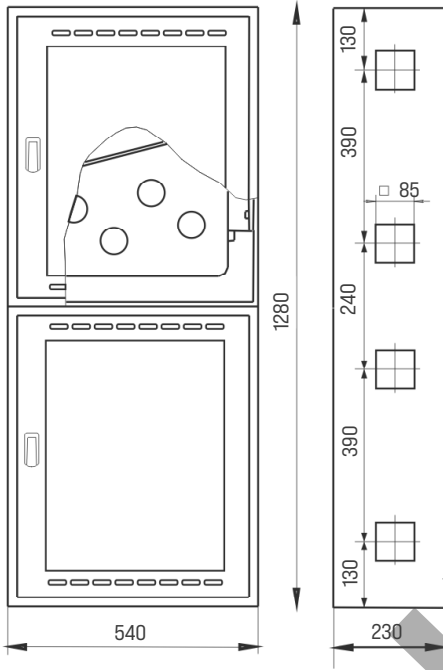

Fig. 4 - Fire Cabinet PRESTIGE wall-mounted

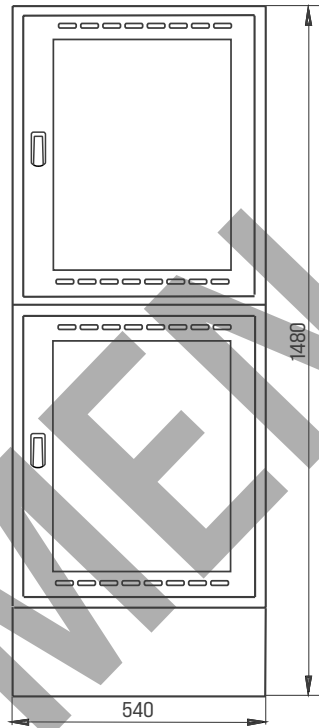

Fig. 6 - Fire Cabinet PRESTIGE floor-mounted

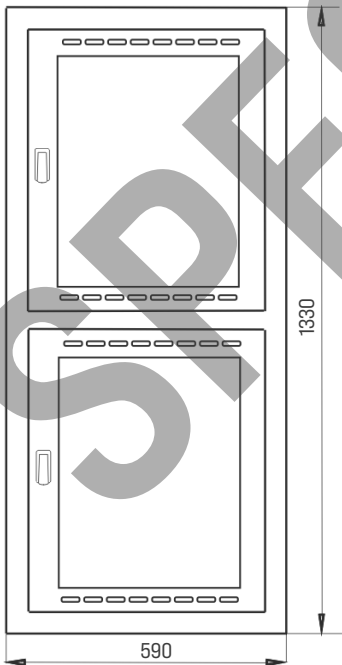

Fig. 5 - Fire Cabinet PRESTIGE recessed

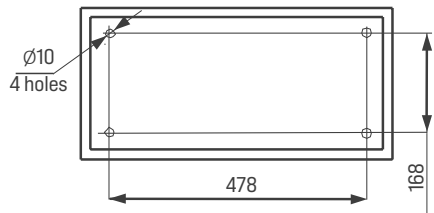

Fig. 7

4. PRODUCT DESIGN

Fire Hose Cabinet Complete Set consists of the fire hose PRESTIGE complete with couplings, fire hose nozzle and fire valve connected with fire hose using the coupling head GM. Fire Hose Cabinet Complete Set is installed into the Fire Cabinet PRESTIGE.

Fire Cabinet PRESTIGE (Fig. 1, 2, 3) consists of the body 1, frame 2, door 3, hose holder 4 used for storage of donut rolled fire hose 5. Fire hose is connected with fire hose nozzle 6 from one side and the fire valve 7 using the coupling head 8 from another side. The door 3 has a lock 9. The hose holder, depending on the location of the pipelines at the site, can be located inside the cabinet in the upper or lower position. On the side surfaces of the body 1, there are four plugs 11, one of which, depending on the location of the pipelines at the site, must be dismantled. Cabinets can be supplied in the red or white finish; with a glass window in the doors or with solid doors.

Figure 1, 2, 3 shows Fire hose Cabinet with a right-sided door of the Fire Cabinet.

To change right-sided door to the left-sided door dismount the hose holder 4 from the body 1. The body 1 shall be turned upside down. Reverse the position of mounting brackets at the hose holder 4 and mount the hose holder 4 inside the body 1.

The manufacturer reserves the right to make changes to the design of the product that do not affect the main technical characteristics.

5. FIRE HOSE CABINET MOUNTING PROCESS

1) ATTENTION! BEFORE THE MOUNTING OF THE FIRE HOSE CABINET UNSCREW THE BOLT SECURING THE HOSE HOLDER AND THE TRANSPORT BRACKET OF THE HOLDER WITH THE CABINET. TURN THE TRANSPORT BRACKET COUNTER-CLOCKWISE AND PULL OUT THE FIRE HOSE PACKAGE.

2) Mounting of the wall-mounted Fire Hose Cabinet PRESTIGE with typical size O3 (Fig. 1) is carried out through the hole A in the back wall of the cabinet.

3) Mounting of the floor-mounted Fire Valve Cabinet PRESTIGE with typical size O3 (Figure 3) is carried out through the holes in the base of the stand of the cabinet 12. The holes position is specified in Figure 7.

4) To mount the built-in Fire Hose Cabinet Complete Set with typical size O3 (Fig. 2) remove the frame 2 from the cabinet. Dismount the plug 11 in the body 1 of the cabinet. Moving the body 1 inside the construction niche insert a branch pipe of the fire pipeline into the unplugged hole in the body, and fix the cabinet body 1 in the construction niche. Fill free space between the body 1 and the walls of the construction niche with mortar. Screw the fire valve 7 to the branch pipe of the fire pipeline. Mount an angle fire valve with a nominal diameter $D_y = 65$ mm using coupling in accordance with GOST 8954, cap nut in accordance with GOST 8969 and locknut in accordance with GOST 8968. Before mounting a direct fire valve with nominal diameter $D_y = 50$ mm unscrew the valve head from the fire valve. Then attach the fire hose 5 to the fire valve using the coupling head 8. Place the fire hose inside the hose holder 4. Attach the fire hose nozzle 6 to the fire hose.

Mount the frame 2 to the body 1. Close the door with the lock 9. Seal the door 3.

After mounting completion of the Fire Hose Cabinet, stick the information sign from the delivery set onto the cabinet door.

6. OPTIONS FOR PLACEMENT OF FIRE HOSE EQUIPMENT IN THE CABINET

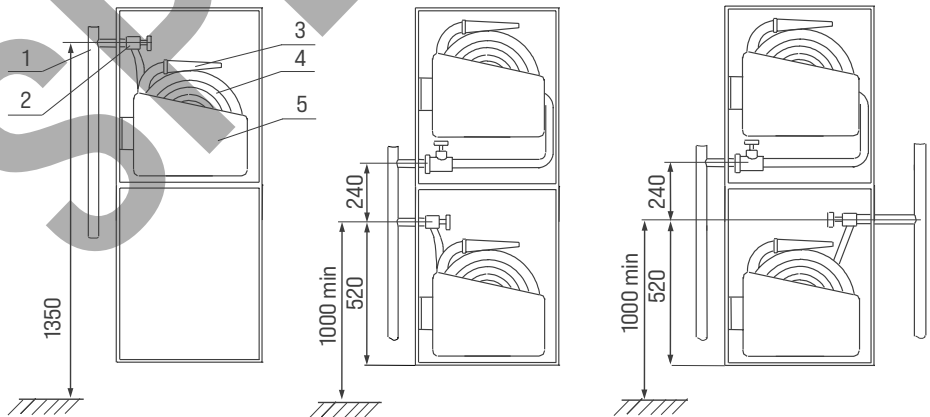

1 – fire pipeline, 2 – valve, 3 – fire hose nozzle, 4 – fire hose, 5 – hose holder

7. OPERATION GUIDELINES

The operating temperature range of the Fire Valve Cabinet is from 5 to 45 °C at relative humidity up to 90%.

Maintenance of the Fire Valve Cabinet is carried out in accordance with paragraph 2.4.3 of GOST 12.4.009.

Mounting is carried out in accordance with building codes and rules, subject to the following requirements:

- the convenience of attaching the fire hose and avoiding sharp bend when laying fire hose in any direction;
- the ease of handling and rotation by hand of the fire hose holder

Twice a year, the fire hose must be turned over, to change the touch points of the hose with the walls of the fire hose holder. Twice a year, the Fire Valve Cabinet is subject to maintenance and performance checks by water launching with the logging of inspection results in the maintenance log book. Fire hose must be dried after extinguishing the fire or checking the performance.

8. TRANSPORTATION AND STORAGE

Packed Fire Hose Cabinet Complete Set can be transported by roofed transport of any kind. Temperature range of transportation and storage is from minus 40 °C to plus 45 °C.

9. RECYCLING

Fire Hose Cabinet Complete Sets are not threatening to the life and health of people and the environment.

After the end of the service life, the used Fire Valve Cabinets are transported to industrial landfills or recycling plants. Non-metallic components should be disassembled and disposed of as household waste.

10. CERTIFICATE OF ACCEPTANCE

Fire Hose Cabinet Complete Set

PRESTIGE-03-WGR-51-RS-50	PRESTIGE-03-RGR-51-RS-50	PRESTIGE-03-FGR-51-RS-50
PRESTIGE-03-WGW-51-RS-50	PRESTIGE-03-RGW-51-RS-50	PRESTIGE-03-FGW-51-RS-50
PRESTIGE-03-WSR-51-RS-50	PRESTIGE-03-RSR-51-RS-50	PRESTIGE-03-FSR-51-RS-50
PRESTIGE-03-WSW-51-RS-50	PRESTIGE-03-RSW-51-RS-50	PRESTIGE-03-FSW-51-RS-50
PRESTIGE-03-WGR-66-RS-70	PRESTIGE-03-RGR-66-RS-70	PRESTIGE-03-FGR-66-RS-70
PRESTIGE-03-WGW-66-RS-70	PRESTIGE-03-RGW-66-RS-70	PRESTIGE-03-FGW-66-RS-70
PRESTIGE-03-WSR-66-RS-70	PRESTIGE-03-RSR-66-RS-70	PRESTIGE-03-FSR-66-RS-70
PRESTIGE-03-WSW-66-RS-70	PRESTIGE-03-RSW-66-RS-70	PRESTIGE-03-FSW-66-RS-70
PRESTIGE-03-WGR-51-RS-50.01	PRESTIGE-03-RGR-51-RS-50.01	PRESTIGE-03-FGR-51-RS-50.01
PRESTIGE-03-WGW-51-RS-50.01	PRESTIGE-03-RGW-51-RS-50.01	PRESTIGE-03-FGW-51-RS-50.01
PRESTIGE-03-WSR-51-RS-50.01	PRESTIGE-03-RSR-51-RS-50.01	PRESTIGE-03-FSR-51-RS-50.01
PRESTIGE-03-WSW-51-RS-50.01	PRESTIGE-03-RSW-51-RS-50.01	PRESTIGE-03-FSW-51-RS-50.01

corresponds to the normative documents requirements, have the stamp of acceptance and are marked as ready for service

Date of manufacture _____

Stamp of acceptance _____

11. MANUFACTURER WARRANTY

The warranty period of storage of the Fire Hose Cabinet Complete Set is 36 months from acceptance date. The warranty period of operation within the warranty period of storage is 24 months from the date of putting the Fire Hose Cabinet Complete Set into operation.

The Manufacturer guarantees that any faults found by the consumer during the warranty period shall be corrected no later than one month after the Manufacturer is notified of said fault. The manufacturer guarantees that the Fire Hose Cabinet Complete Set corresponds to specifications stated, provided that the user complies with the operation, transportation, and storage rules.

The Manufacturer does not bear responsibility in cases of non-compliance by the owner of the operating rules and loss of the product certificate.